



ACL

Manufacturing

A Division of ClearRushCo.



ACL High Efficiency Burner

PATENTED

Model: HE Burner

The **ACL High Efficiency Burner** is a patented Burner Assembly that achieves typically 80% combustion efficiency, resulting in significant fuel savings. The ACL HE Burner Assembly incorporates safe and reliable ignition and flame sensing, creates a unique flame profile that maximizes heat transfer, inhibits flame lift-off and eliminates impingement. These features combine to produce a cleaner burn and increases longevity of process equipment.

The ACL HE Burner Assembly includes the high aspiration mixer, venturi, and optimizer nozzle.

The compact design along with the unique secondary air plate results in lower emissions (CO, NO_x, and Co₂), VOCs (Volatile Organic Compounds), and noise pollution.

Custom options and sizing available for a variety of applications.

HE Burner with Separate M50A Pilot

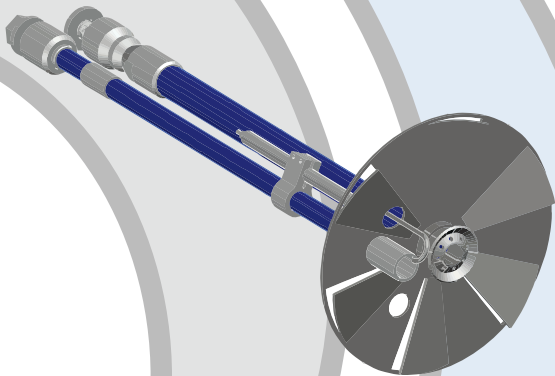

New Venturi Design

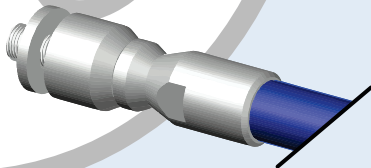

Optional Mixer Sleeve

A Mixer sleeve option may be added to perform a variety of functions:

- Heat Return tube to prevent freeze ups
- Flue Gas re-circulation to lower NO_x
- BTEX connection to burn waste gas

(See product specification sheet on reverse)

www.clearrushco.com

1-877-638-5234 (403) 638-5234

Clear Rush Co.
Box 1898, 5406 Township Road 325B
Sundre, AB T0M 1X0
Canada



ACL

Manufacturing

A Division of ClearRushCo.

ACL High Efficiency Burner

PATENTED

Model: HE Burner

Specifications

Standard Material - Nozzle, secondary air plate, threaded pipe	12 Gauge carbon steel
Standard Material - Mixer, venturi	Aluminum
Optional Material - Nozzle, secondary air plate	304 L Stainless Steel
Operating Pressure	0.5 - 15 psi

Sizing

1" NPT Assembly	Up to 1 MM BTU
1.5" NPT Assembly	Up to 1.5 MM BTU
2.0" NPT Assembly	Up to 2.5 MM BTU
2 x 1.5" NPT Assembly	Up to 3 MM BTU
2 x 2.0" NPT Assembly	Up to 5 MM BTU
3 x 2.0" NPT Assembly	Up to 7.5 MM BTU
6 x 2.0" NPT Assembly	Up to 15 MM BTU

Multiple Burner Nozzles

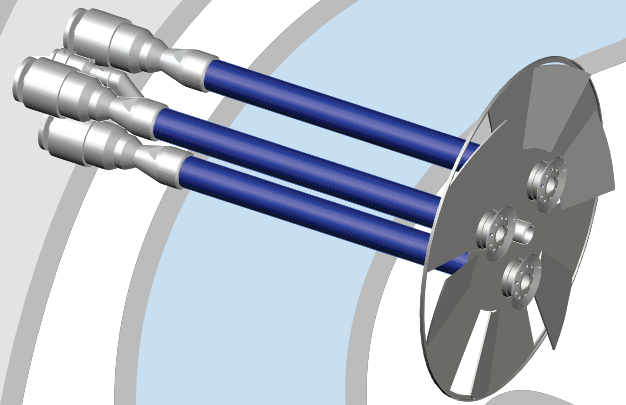

Slipstream Burner With Heat Return

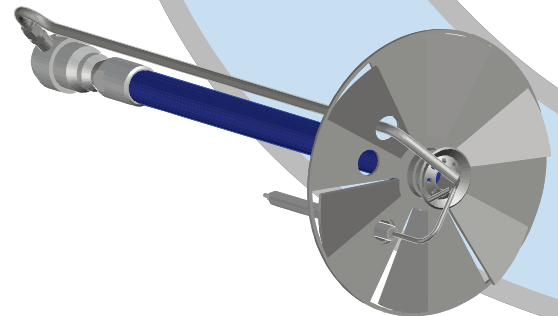

HE Mixer/Venturi Assembly With Mixer Sleeve

Heat Return / BTEX / Recirculation Port

Air Adjust Nut

Mixer Sleeve

Mixer

New Venturi

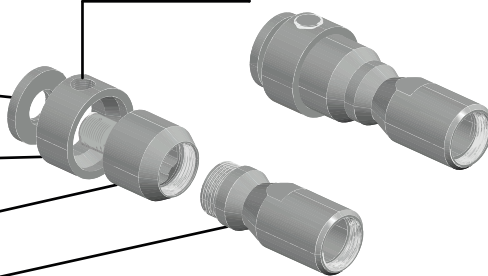

www.clearrushco.com

1-877-638-5234 (403) 638-5234

Clear Rush Co.
Box 1898, 5406 Township Road 325B
Sundre, AB T0M 1X0
Canada